

The WP150 is a high performance, long life, severe duty electric water pump used in cooling systems in extreme environments. It can be used in off road applications, power generation, and large vehicle applications including fuel cell, diesel, electric, and other alternative fuel applications.



APPLICATIONS

Fuel Cell	EGR
Traction Motor	CAC
Hybrid Battery Pack	Electronics
Hydraulic	HVAC

FEATURES

- 500-850 VDC
- Full variable speed control
- Long-life brushless DC motor
- Sealed and fully submersible
- High efficiency, compact, and quiet

PUMP SPECS

Flow & Pressure	75 GPM @ 22 psi
Pump Speed Range	500 - 4350 RPM
Overall Weight	16lbs (7.25 kg)
Operating Temperatures	-40° to 203° F (95° C)
Storage Temperatures	-40° to 257° F (125° C)
Sealing Rating	IP6K9K
Hose Connections	2 in

CONTROLLER SPECS

Control Input	SAE J1939-11 Autobaud CAN
LV Range	9 - 32 VDC
HV Range	500 - 850 VDC
LV Connection	TE 5ATM 12 Pin w/ bonding wire
HV Connection	TE HV280A w/HVIL
LV Current	200 mA @ 24 V 203° F
HV Current	5 AMP Maximum

CONTACT US ABOUT YOUR HIGH VOLTAGE APPLICATIONS

EMP's popular 15" electric fan has developed a high-voltage option. These fans run on a range of 450 – 850V with 1.5 – 3kw of power, CAN controlled with variable speed, and diagnostic capable. It's power distribution module also allows for a "plug and play" single point connection for easy integration.



FEATURES

450 - 850 Volts

Galvanic isolation between LV and HV

Integrated Controller

Fully controllable single speed

Motor & Controller diagnostics

Active/passive discharge

Pusher or puller configurations

E-Mark certified

SIMPLIFIED ARCHITECTURE

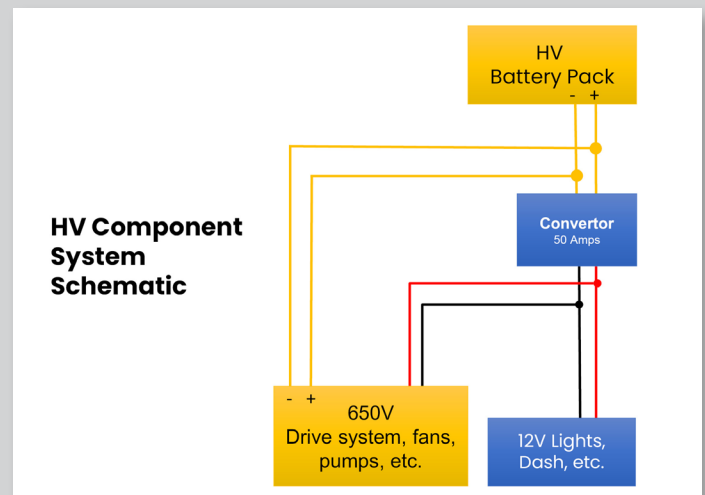
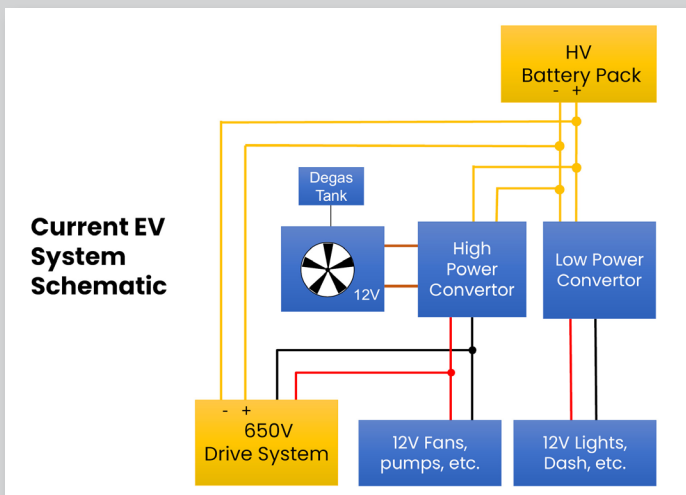

FAN SPECS

Airflow	3400 m3/hr @ 250 Pa
Max Fan Speed	500 - 3400 RPM
Size & weight	15" blade & 16lbs
Operating Temperatures	-40° to 95° C
Storage Temperatures	-50° to 125° C
Sealing Rating	IP6K9K
Fan Life	40,000+ hours
Finger Guard Available	SAE J1308
Materials	All aluminum outer housing
Materials	Glass filled plastic blade

CONTROLLER SPECS

Control Input	SAE J1939-11 Autobaud CAN
LV Range	9 - 32 VDC
HV Range	450 - 850 VDC
LV Connection	TE 5ATM 12 Pin w/ bonding wire
HV Connection	TE HV280A style w/HVIL
LV Current	200 mA @ 24 V 203° F
HV Current	3 Amps Continuous @ 450 V, 203° F
Protection From...	Current limit, over temp
Protection From...	Transients/short circuit/reverse battery